

MECHANICAL SEAL PIPING PLANS

API PLAN 11 - API PLAN 13 - API PLAN 21 - API PLAN 23 - API PLAN 32 - API PLAN 51 - API PLAN 52 - API PLAN 53A

API PLAN 53B - API PLAN 53C - API PLAN 54 - API PLAN 55 - API PLAN 61 - API PLAN 62 - API PLAN 76



API PLAN 11

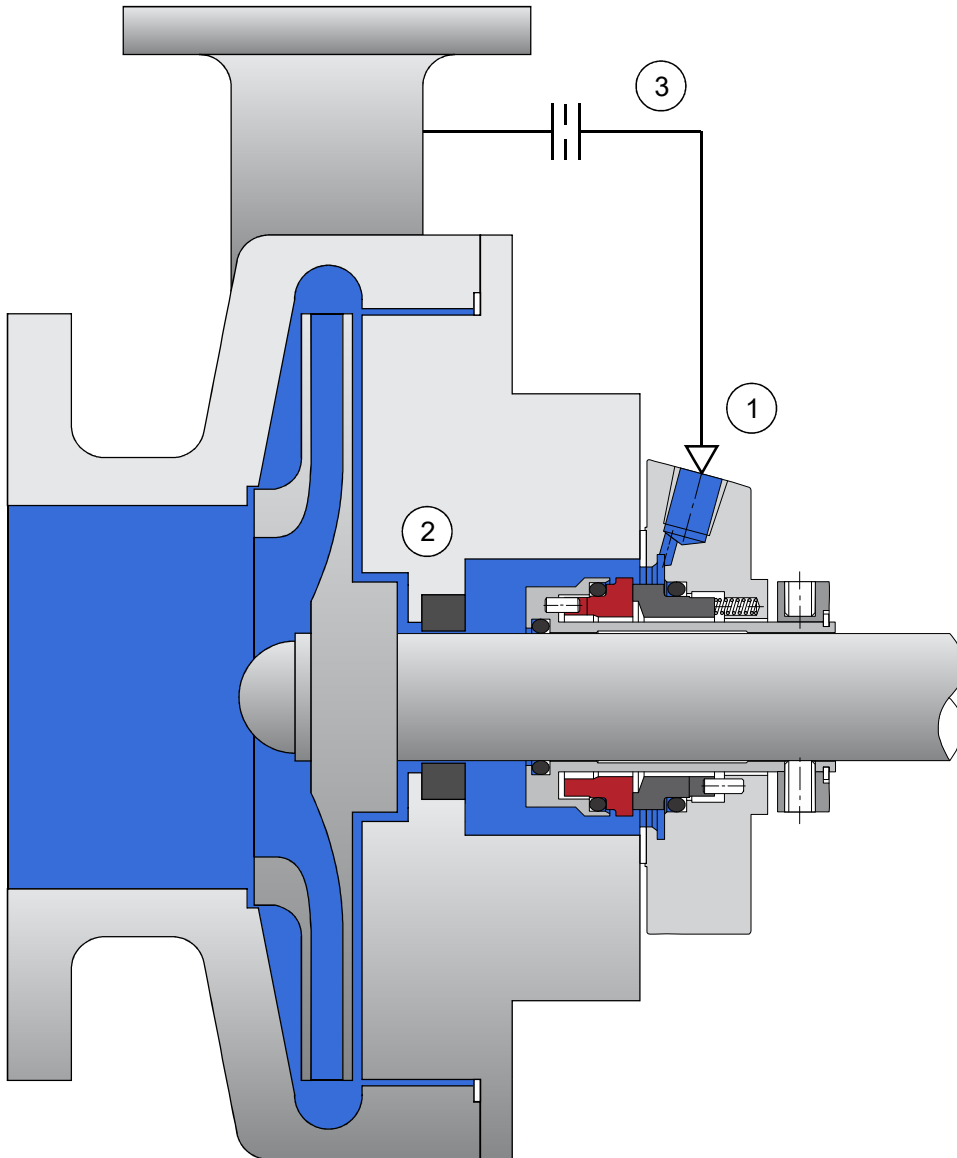

Description:

Plan 11 is the default flush plan for most single mechanical seals. Plan 11 uses fluid from the pump discharge through an orifice and directs it to the seal chamber through the flush port of the mechanical seal, increasing lubricity to the seal faces and reducing heat in the seal chamber.

Features:

- Default flush plan for most single mechanical seals.
- Removes heat from seal chamber.
- Ensures proper pressure in seal chamber to prevent fluid vaporizing.
- Allows seal chamber to be self-venting when used with horizontal pumps.
- Utilizes a restriction bush for better efficiency.

Notes:

- Orifice size should be a minimum of 3.2mm (1/8").
- Discharge and seal chamber pressure must be checked to ensure proper flow of fluid.
- The orifice and restriction bush clearance must be checked to ensure proper flow of fluid to the mechanical seal.

Key:

1. Flush Port
2. Restriction Bush
3. Orifice



API PLAN 13

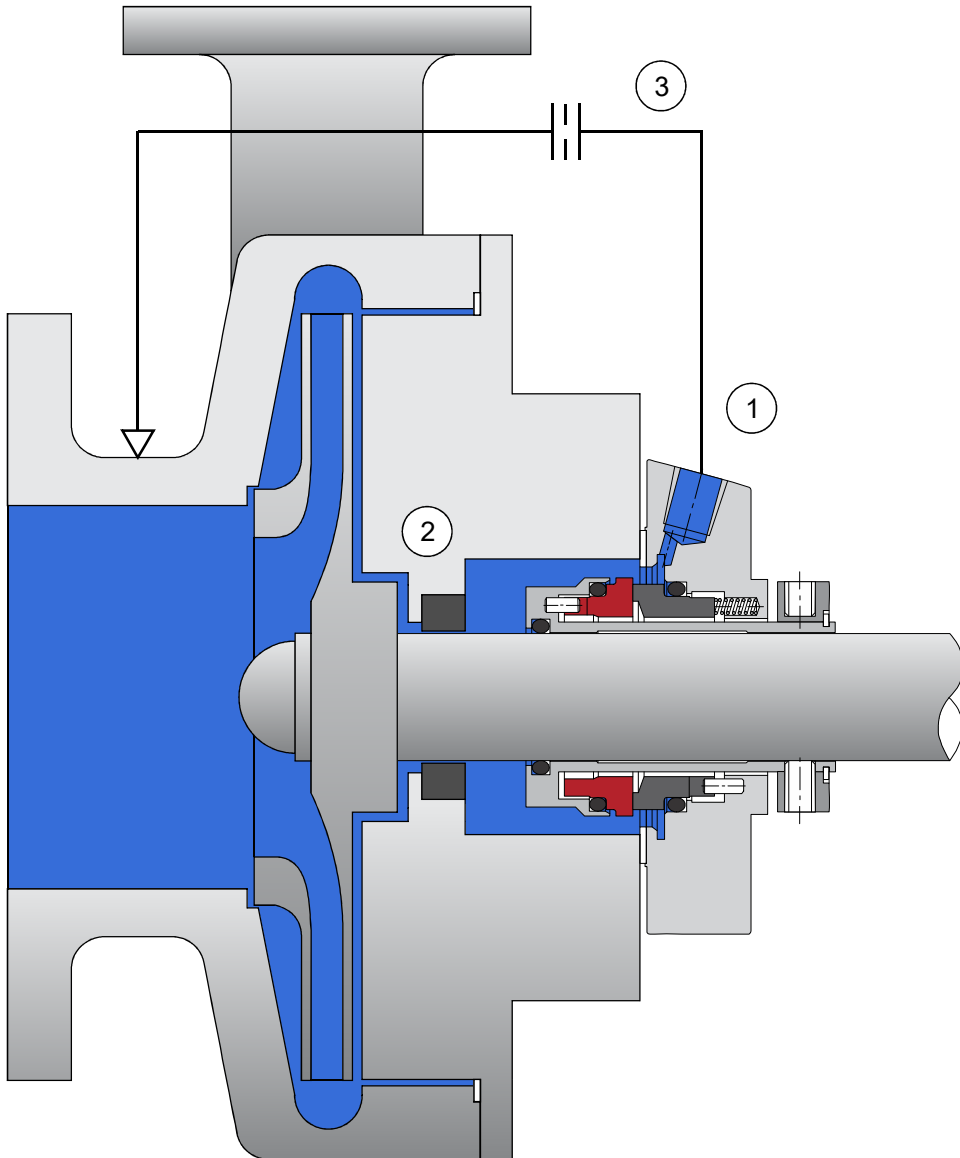

Description:

Plan 13 recirculates product from the seal chamber, through a flow control orifice, to the pump suction. Standard flush plan for vertical and high head pumps.

Features:

- Removes heat from seal chamber.
- Allows seal chamber to be continually self-venting when used with vertical and high head pumps.
- Relieves pressure in the seal chamber.

Notes:

- Orifice size should be a minimum of 3mm (1/8").
- The seal chamber pressure must be checked to ensure proper flow of fluid as a higher flow rate is required to efficiently remove heat.
- The orifice and restriction bush clearance must be checked to ensure proper flow of fluid to the mechanical seal.

Key:

1. Flush Port
2. Restriction Bush
3. Flow Control Orifice



API PLAN 21

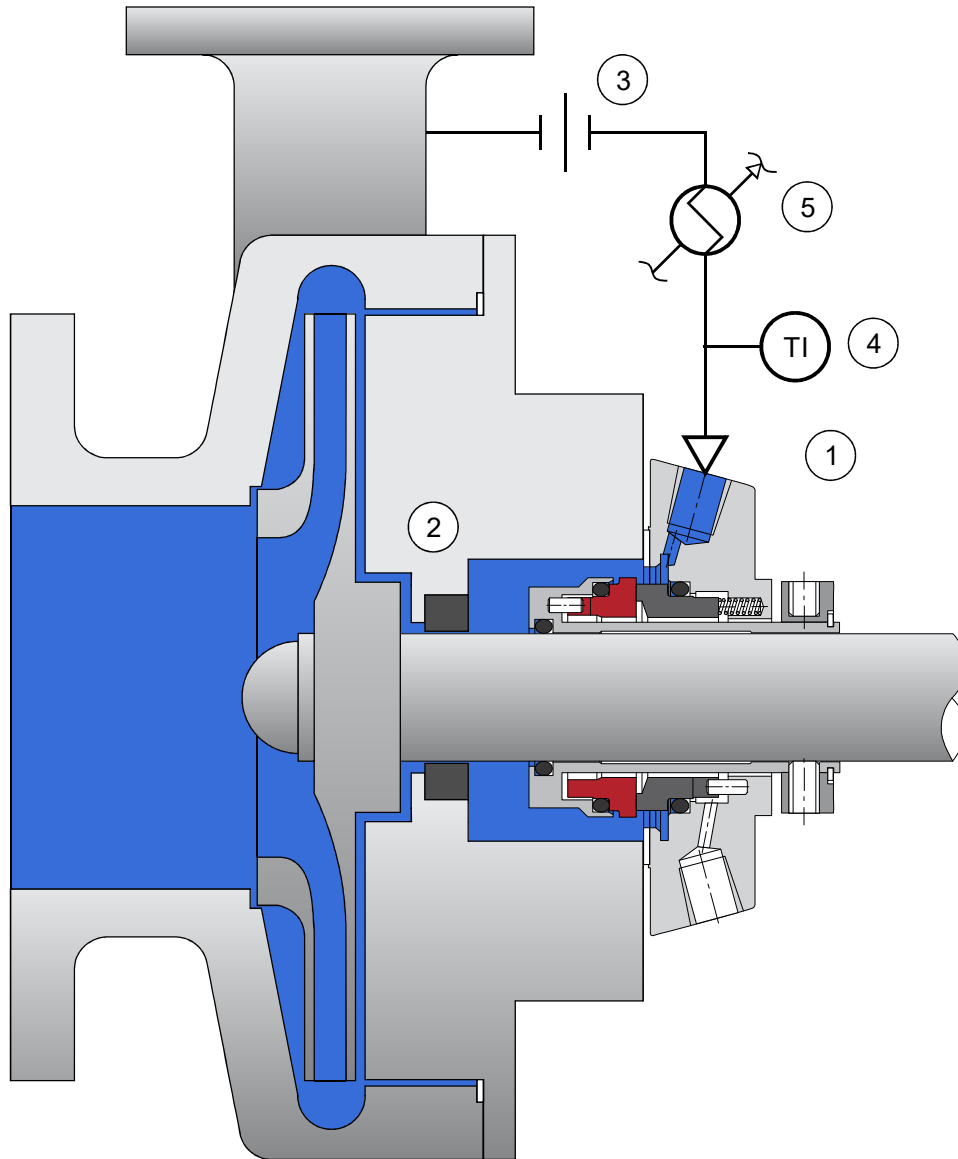

Description:

Plan 21 follows the same principle as Plan 11 (from discharge through orifice to seal chamber) with the addition of a heat exchanger to assist cooling down the seal chamber.

Features:

- Plan 21 is self venting
- Used to improve lubricity in high temperature applications
- Utilizes a restriction bush for better efficiency.

Notes:

- Orifice size should be a minimum of 3.2mm (1/8").
- Discharge and seal chamber pressure must be checked to ensure proper flow of fluid.
- The orifice and restriction bush clearance must be checked to ensure proper flow of fluid to the mechanical seal.
- Heat Exchanger must always be placed after the orifice.
- Potential plugging on the process side if the liquid viscosity rises quickly.

Key:

1. Flush Port
2. Restriction Bush
3. Orifice
4. Heat Exchanger
5. Temperature indicator



API PLAN 23

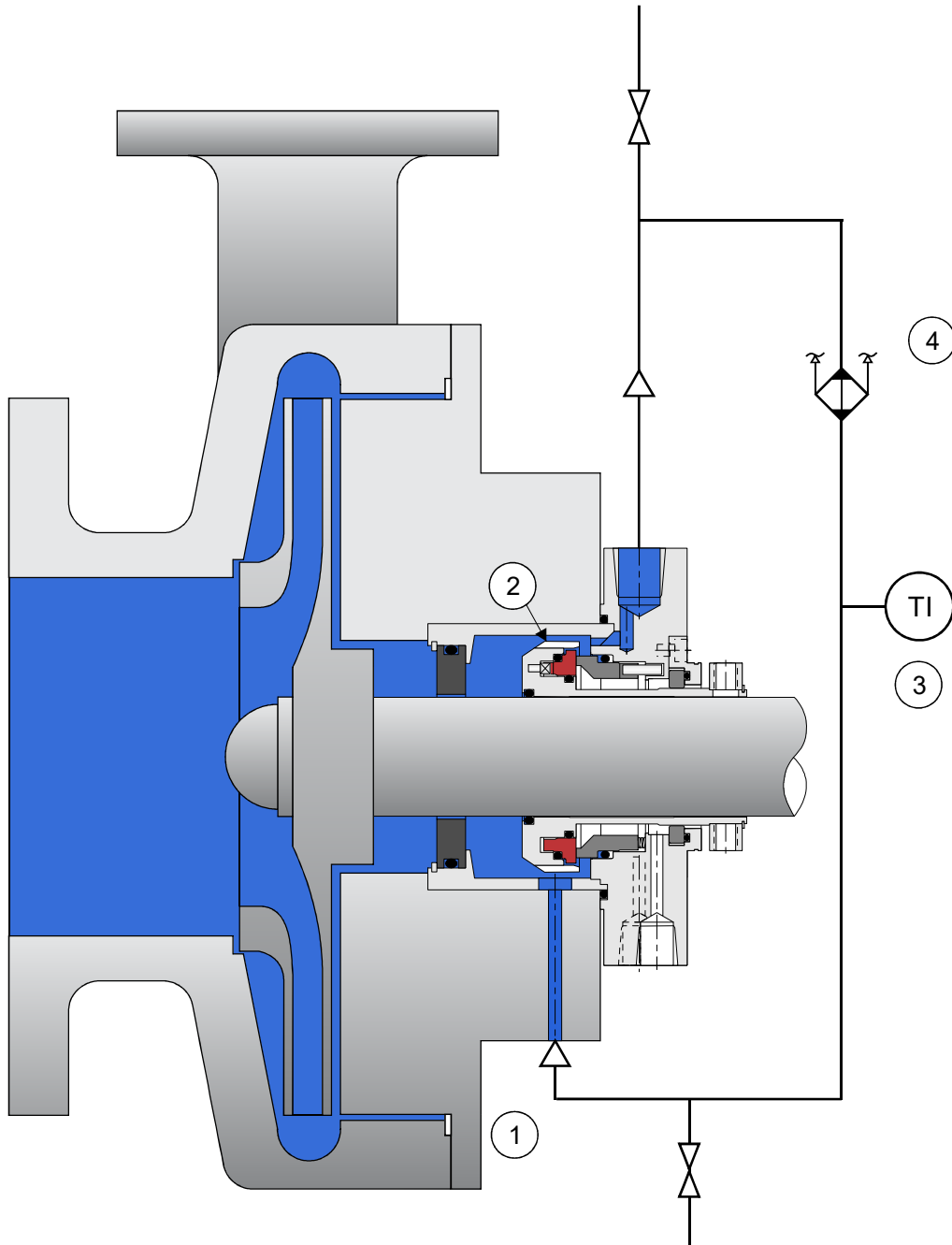

Description:

Plan 23 is a product recirculation plan, designed using a pumping scroll and a heat exchanger to assist with temperature control in the seal chamber.

Features:

- Plan 23 introduces a pumping device.
- Uses a flush system to remove heat generated by faces.
- Application setup ensures the circulation process of Thermosiphoning is effective.

Notes:

- High vent point is recommended to vent the system before start up.
- Avoid the use of sharp bends (90° elbows) in setup. Piping should be smooth and continuously rising.
- Heat exchanger should be $\pm 500\text{mm}$ above the pump centerline.

Key:

1. Flush
2. Circulation Scroll
3. Temperature indicator
4. Heat Exchanger



API PLAN 32

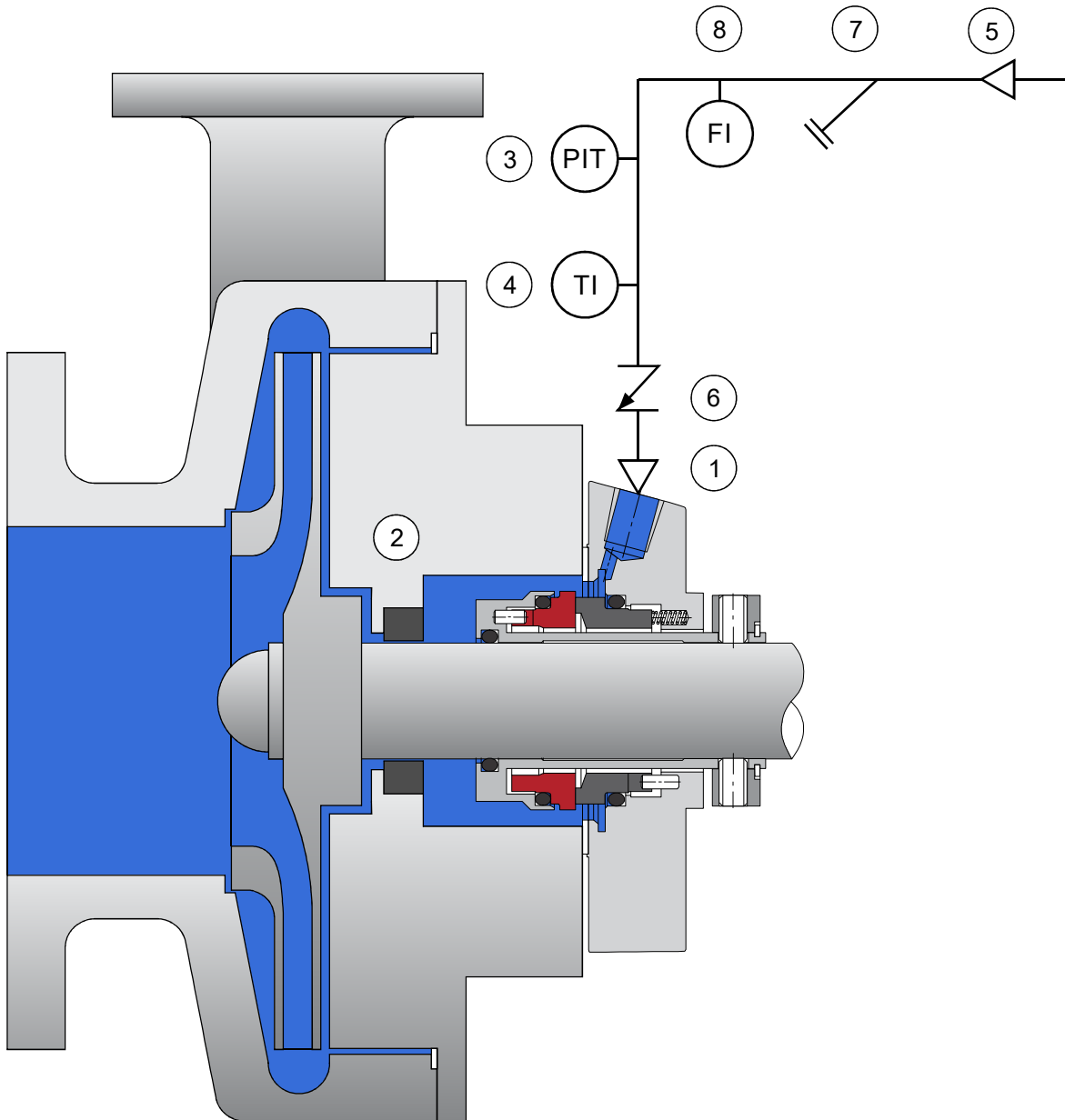

Description:

Plan 32 introduces a clean and/or cool continuous flush in conjunction with a restriction bush.

Features:

- Removes process fluid and solids from seal chamber.
- Increases seal chamber pressure, reducing flashing.
- Reduces seal chamber temperature.
- Suitable for single seals (if product can be diluted).

Notes:

- External Flush must be compatible with the product.
- Flush media should run continuously (even during start up and shut down).
- Pressure of external flush should be regulated at a higher pressure than product pressure.
- Horizontal or vertical flush pump arrangement.

Key:

1. Flush Port
2. Restriction Bush
3. Pressure Indicator and Transmitter
4. Temperature Indicator *
5. External Source
6. Check Valve
7. Y-Type Strainer
8. Flow Indicator *

* Optional

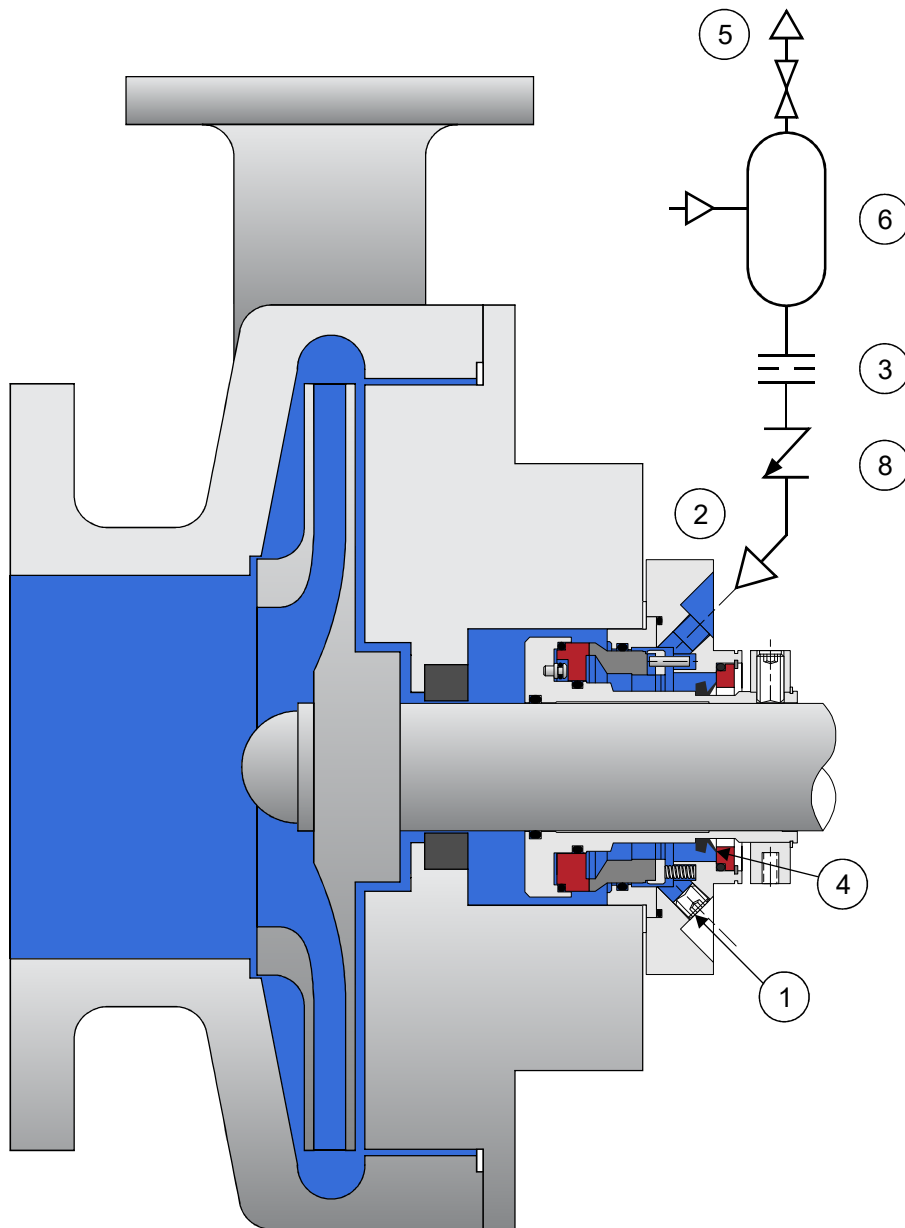

Description:

Plan 51 makes use of an external reservoir providing a dead-end blanket of buffer fluid to the quench connection of the gland.

Features:

- Can be used to prevent crystallization or icing on atmospheric side of mechanical seal.
- No direct process fluid leakage into the atmosphere.

Notes:

- Ensure correct auxiliary sealing device is selected to prevent blanket fluid leakage.
- Keep the external reservoir vent continuously open in order to maintain blanket fluid pressure.
- Always ensure an adequate amount of buffer fluid is available.
- Vent system before start-up.

Key:

1. Drain (Plugged)
2. Quench
3. Orifice
4. Auxiliary Sealing Device
5. Collection system (vapour)
6. External Reservoir



API PLAN 52

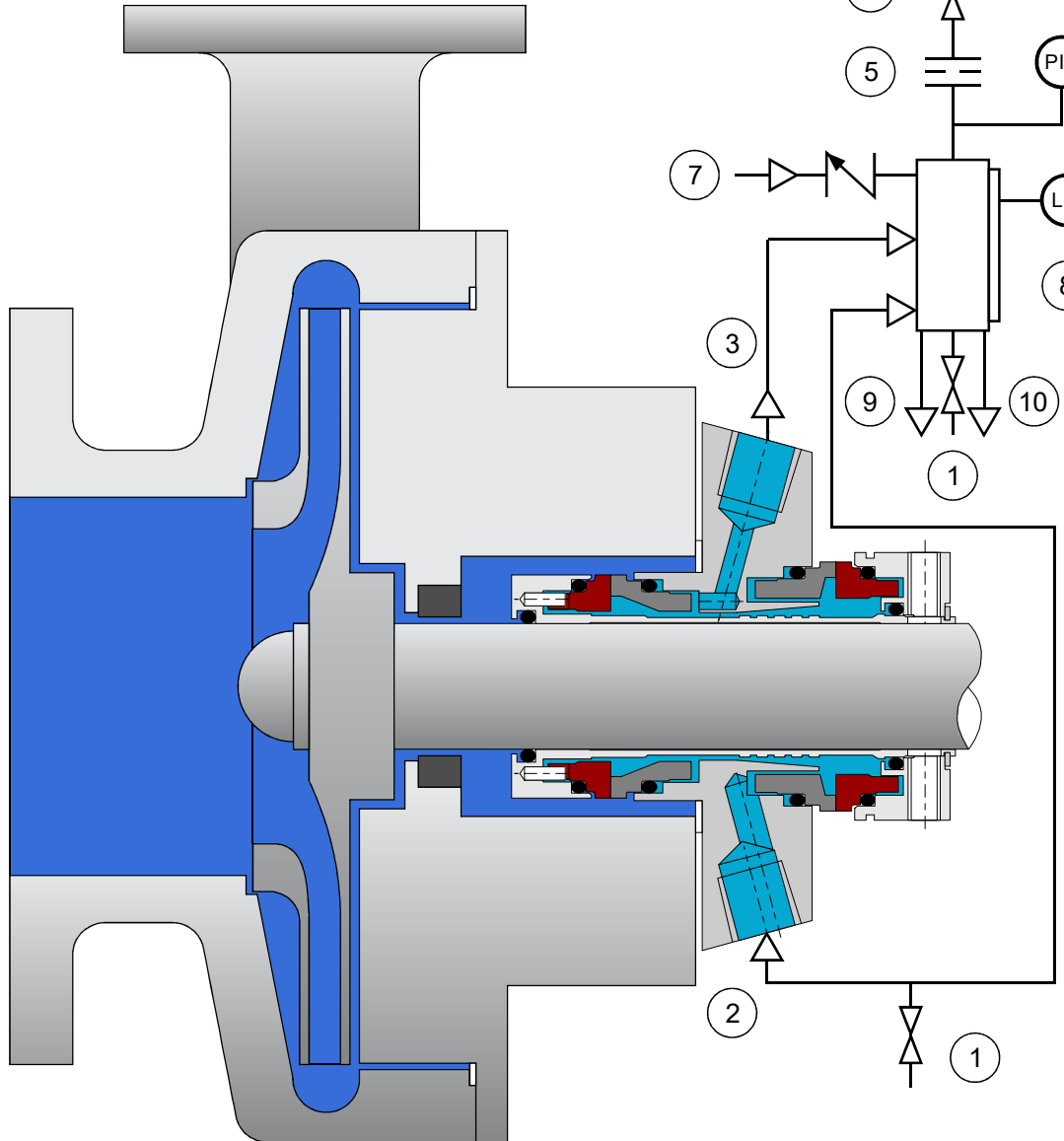

Description:

Plan 52 uses an external reservoir to provide buffer fluid for the outboard faces of a unpressurized dual seal arrangement. Flow direction is created by use of a pumping scroll.

Features:

- Provides lubrication and cooling to the outboard faces
- Product will not be contaminated
- Product does not leak directly into atmosphere
- Using a coil inside the heat exchanger focuses on temperature control
- A pumping scroll ensures there is circulation of the buffer fluid

Notes:

- Orifice in the vent line maintains pressure in the reservoir
- Vent the system before start up (After start up, connect the vent line to the collection line - external source - while system is running)
- Difference in the temperature between inlet and outlet arms indicates proper flow
- Increase in reservoir pressure indicates inboard seal leakage
- Ensure compatibility of product and buffer fluid
- Buffer fluid approximately 2.8 bar lower than product pressure
- Buffer fluid should be checked regularly and replaced when needed

Key:

1. Drains
2. Buffer In
3. Buffer Out
4. Collection Valve
5. Orifice
6. Pressure indicator and transmitter
7. Check Valve
8. Level Indicator and transmitter
9. Cooler line In
10. Cooler line Out



API PLAN 53A

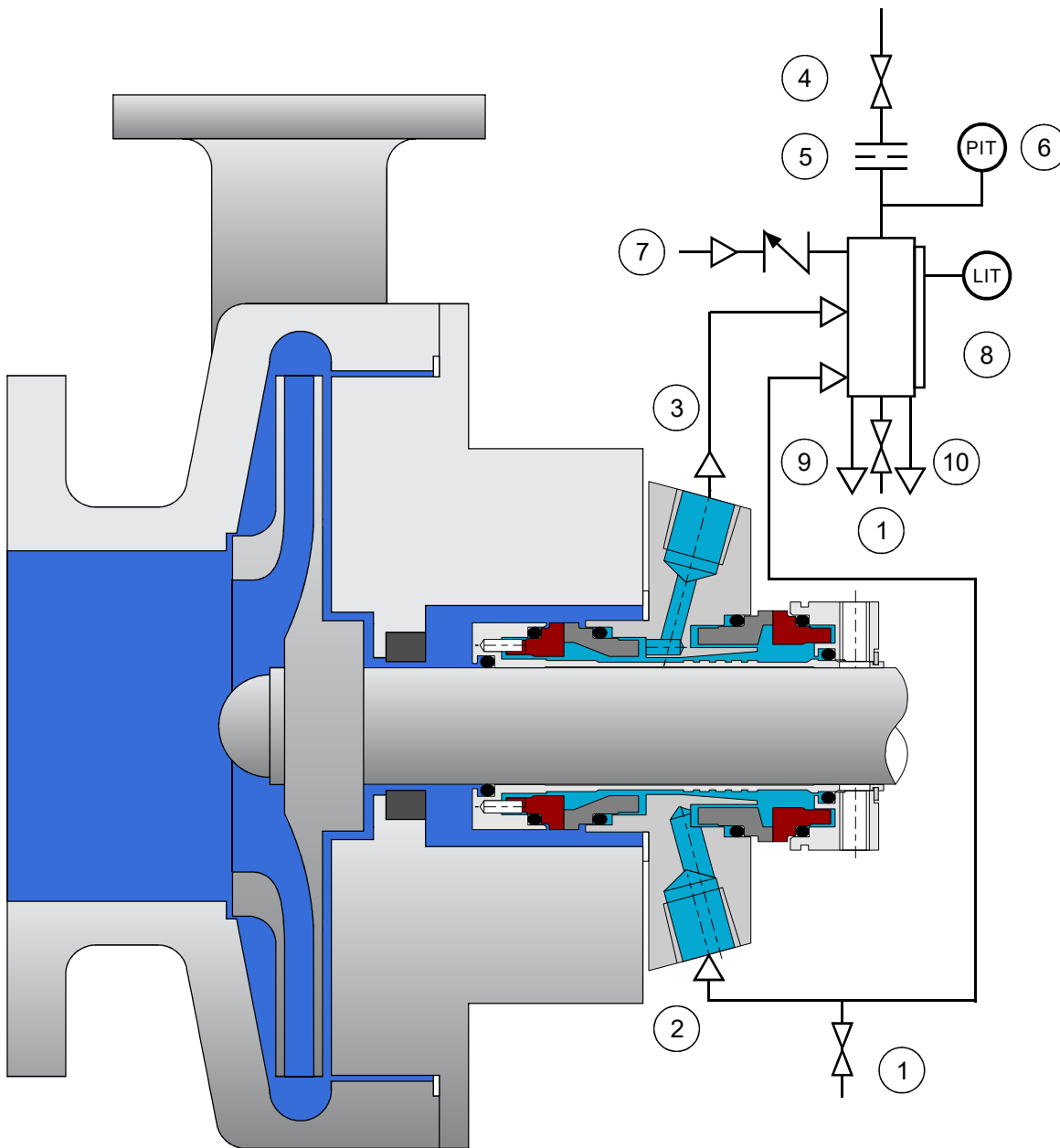

Description:

Plan 53A uses an external reservoir to provide Barrier fluid for a pressurized dual seal arrangement. Reservoir pressure is maintained by a gas (Nitrogen gas)

Features:

- The pumped media never leaks into the atmosphere unless the reservoir pressure is lost
- A cooling coil inside the reservoir (water or air) focuses on heat removal
- A circulation scroll is used to circulate the barrier fluid

Notes:

- Vent the system before start up
- Difference in the temperature of the Inlet and Outlet lines indicates proper flow
- Decrease in the reservoir level indicates leakage on the inboard, outboard or both sides of the seal
- Ensure barrier pressure is a minimum of 1.4 bar higher than the seal chamber pressure
- Maximum pressure of barrier fluid is 16 bar
- Nitrogen source is required for pressurization

Key:

1. Drains
2. Barrier In
3. Barrier Out
4. Orifice
5. Pressure indicator and transmitter
6. External pressure source
7. Check valve
8. Level indicator and transmitter
9. Cooler line In
10. Cooler line Out



API PLAN 53B

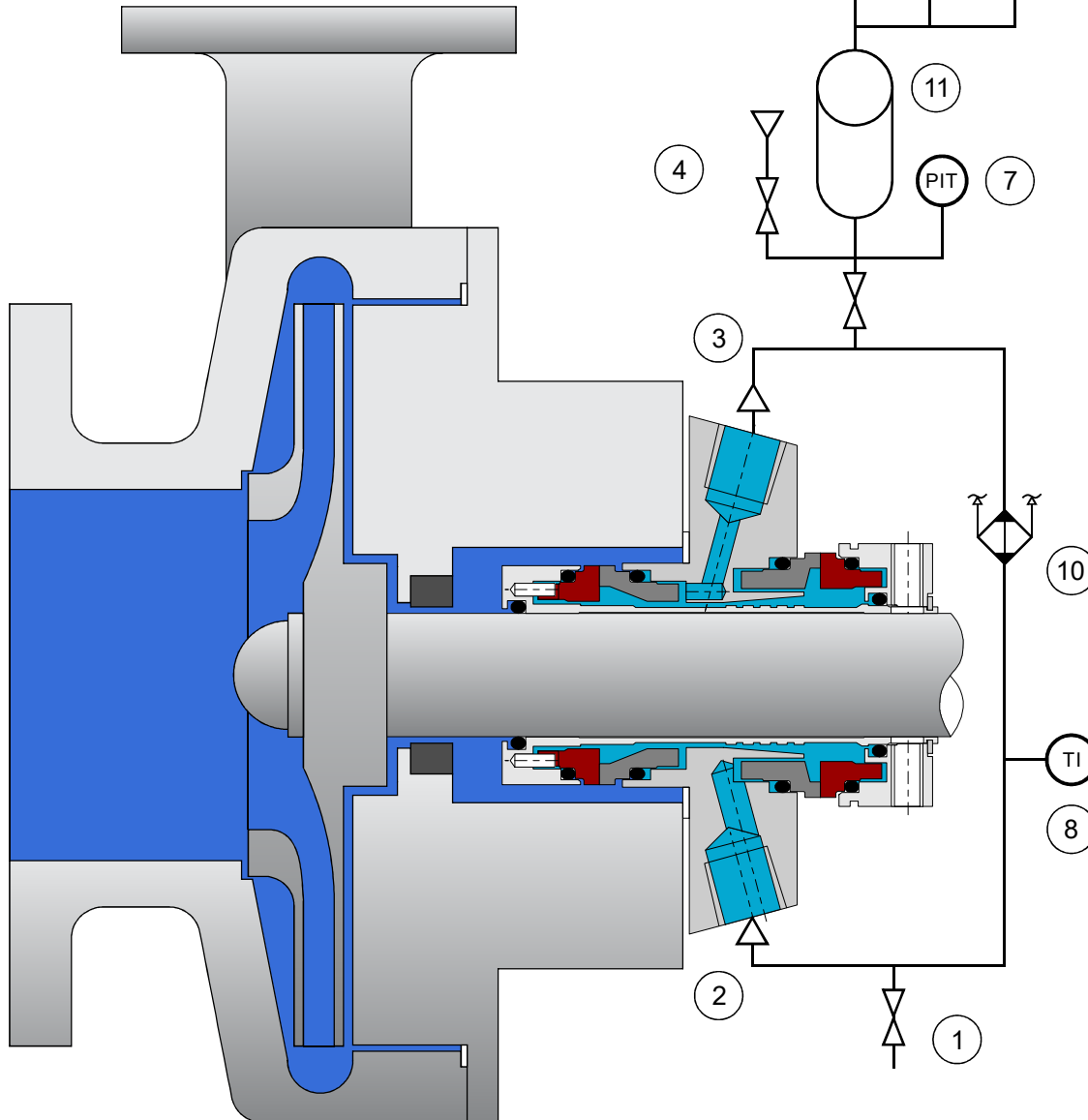

Description:

Plan 53B uses a bladder accumulator to isolate the pressurizing gas from the barrier fluid. A heat exchanger is included in the circulation loop to cool the barrier fluid.

Features:

- A bladder accumulator is introduced into the system to prevent the barrier fluid and the Nitrogen gas from mixing
- The pumped media never leaks into the atmosphere unless the reservoir pressure is lost
- Uses a cooling coil inside of the reservoir to focus on heat removal

Notes:

- Vent the system before start up (close the vent line later on)
- Does not require a permanent Nitrogen source
- Difference in the temperature between the inlet and outlet lines
- For applications where barrier pressure is above 16 bar (minimum 1.4 bar)
- Always pre-charge the bladder at the correct pressure to ensure the required barrier pressure at operating temperature

Key:

1. Drain
2. Barrier In
3. Barrier Out
4. Vent
5. Collection Valve
6. Pressure Indicator
7. Pressure Indicator and transmitter
8. Temperature indicator
9. Temperature indicator and transmitter
10. Heat Exchanger
11. Bladder accumulator



API PLAN 53C

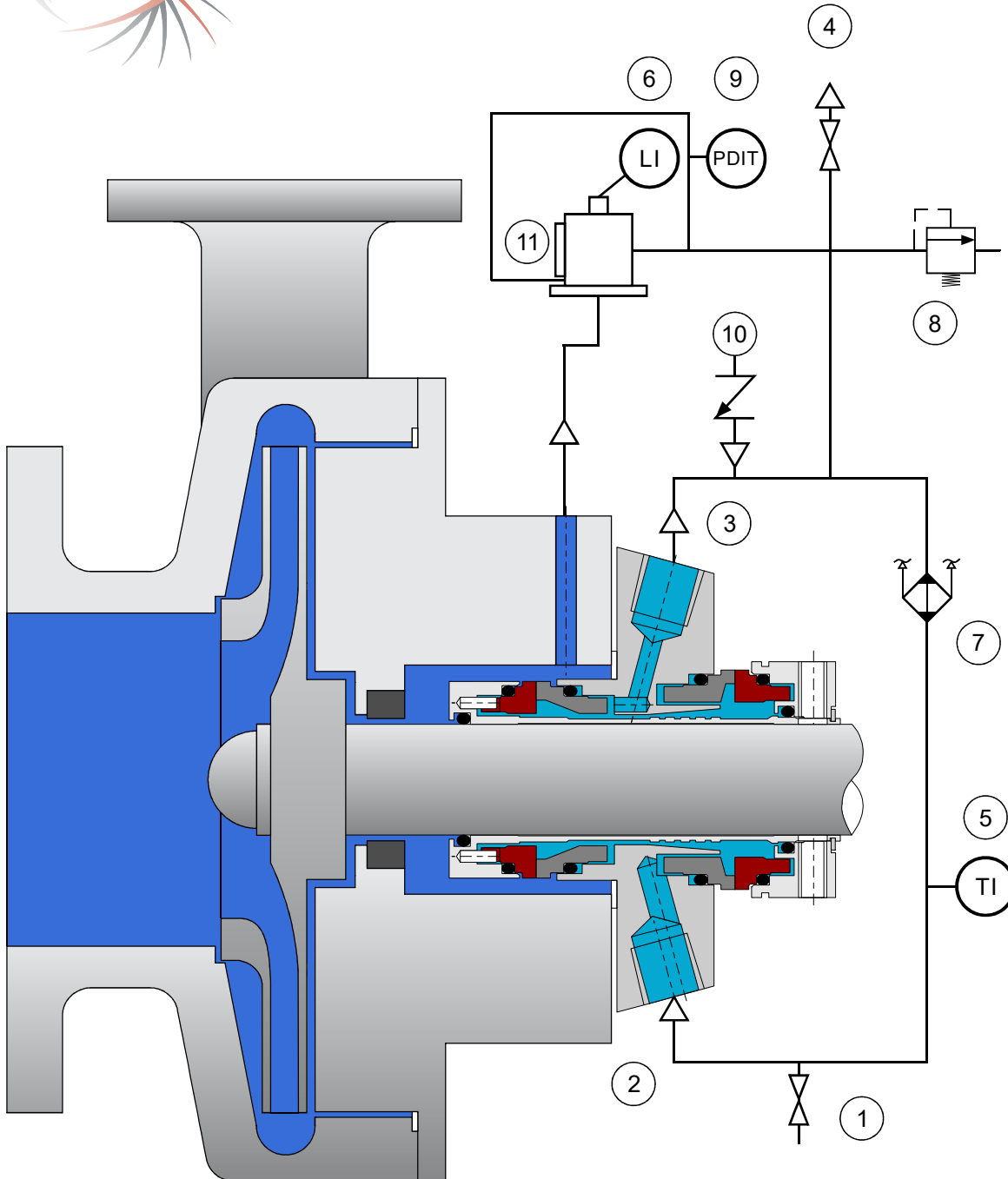

Description:

Plan 53C uses a piston accumulator to provide pressure to the system by using a reference line from the seal chamber to provide a constant pressure differential. A heat exchanger is also used in this plan to cool the barrier fluid.

Features:

- A Piston accumulator dynamically adjusts the barrier pressure based on the seal chamber pressure maintaining a fixed difference across the inboard faces
- Using a coil inside the heat exchanger focuses on temperature control
- Best suited for applications where the stuffing box pressure ranges from 4 to 40 bar

Notes:

- Vent the system before start up (Close the vent line later on)
- Difference in the temperature between inlet and outlet arms indicates proper flow
- Great for applications where the product cannot be used to flush the faces
- Ensure the seal chamber line is not blocked and is connected to the downstream of the accumulator
- Ensure the correct materials are used within the accumulator are compatible with the product

Key:

1. Drains
2. Barrier In
3. Barrier Out
4. Vent
5. Temperature indicator
6. Level indicator
7. Heat Exchanger
8. Pressure Relief Valve
9. Pressure Differential Indicator and transmitter
10. Make-up Barrier Fluid
11. Piston Accumulator



API PLAN 54

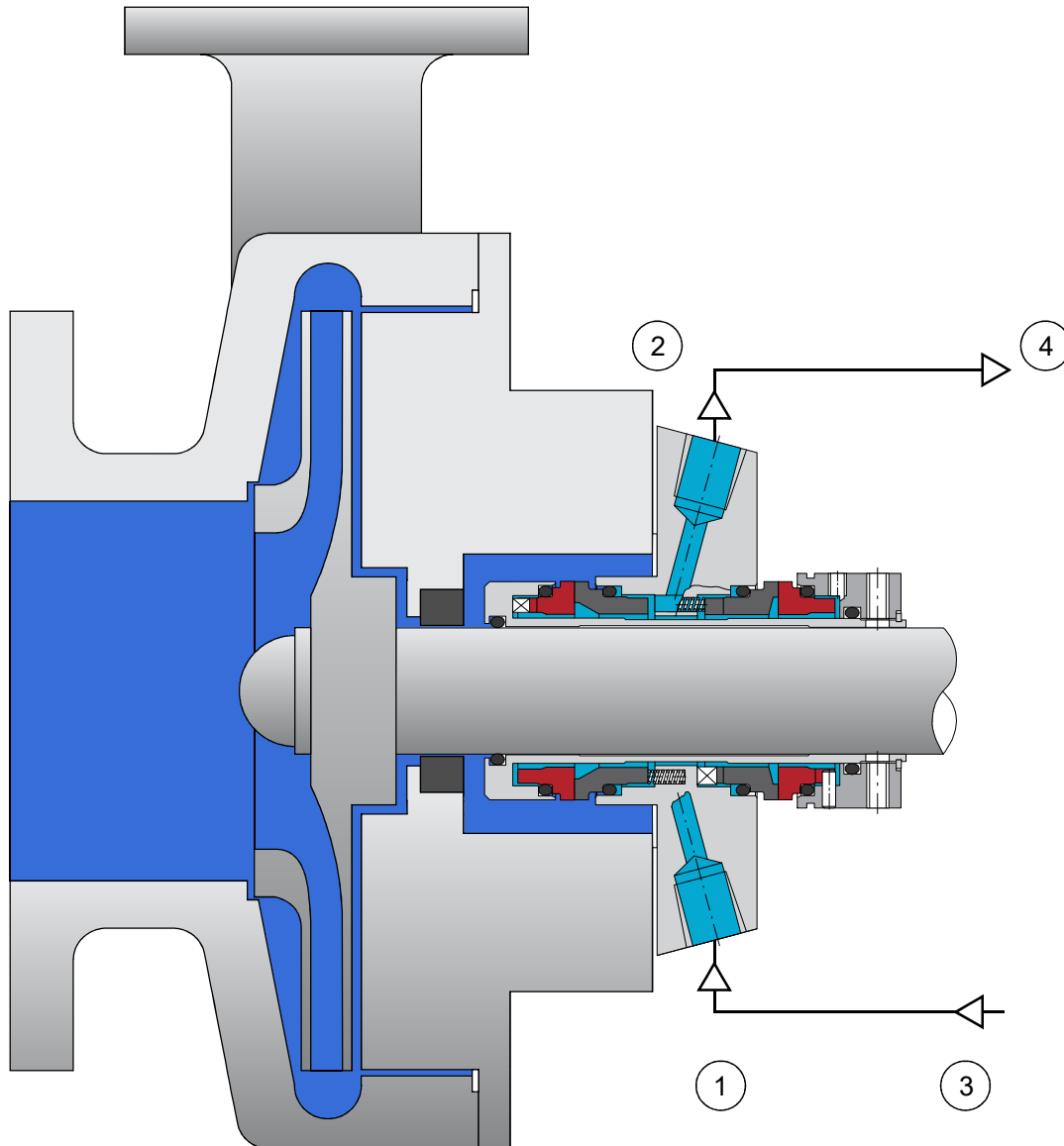

Description:

Plan 54 uses an external source to provide a clean pressurized barrier fluid even if the pump remains on Stand-by.

Features:

- Provides barrier fluid and circulation and cooling even if the pump is on stand-by
- Heat is removed with the help of a water cooler or air cooler
- Best suited for systems where a flush cannot be used for the inner faces

Notes:

- System setup is great for Hot applications
- Check barrier fluid compatibility with the product
- Where the system uses a filter or strainer, check for blockages
- Ensure the barrier pressure is approximately 2 bar higher than the seal chamber
- Plan 54 needs specific engineering based on application

Key:

1. Barrier In
2. Barrier Out
3. Line from external source
4. Line to external source



API PLAN 55

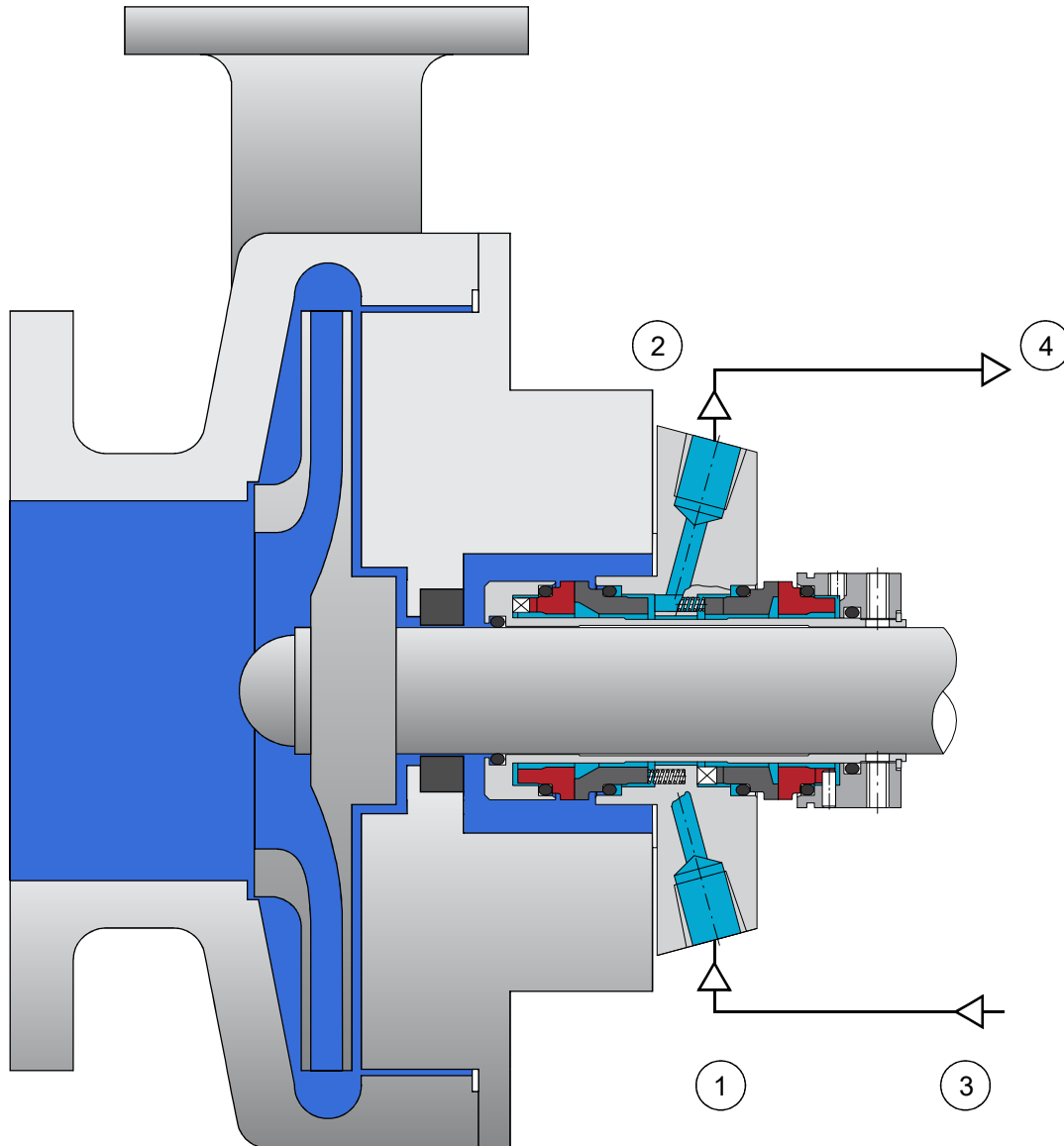

Description:

Plan 55 uses an external source to provide a clean unpressurized buffer fluid to a system separating the product and atmosphere.

Features:

- Uses an external source to circulate the buffer fluid
- Provides cooling and lubrication to the outboard faces
- Suitable for situations where hazardous product cannot leak directly into the atmosphere

Notes:

- Buffer fluid to be at a lower pressure than the product pressure (2.8 bar lower)
- For applications where medium to high temperatures are generated between the faces
- Product must be compatible with the buffer fluid
- Difference in the temperatures between the inlet and outlet arms indicates proper flow

Key:

1. Buffer Inlet
2. Buffer Outlet
3. Line from external source
4. Line to external source



API PLAN 61

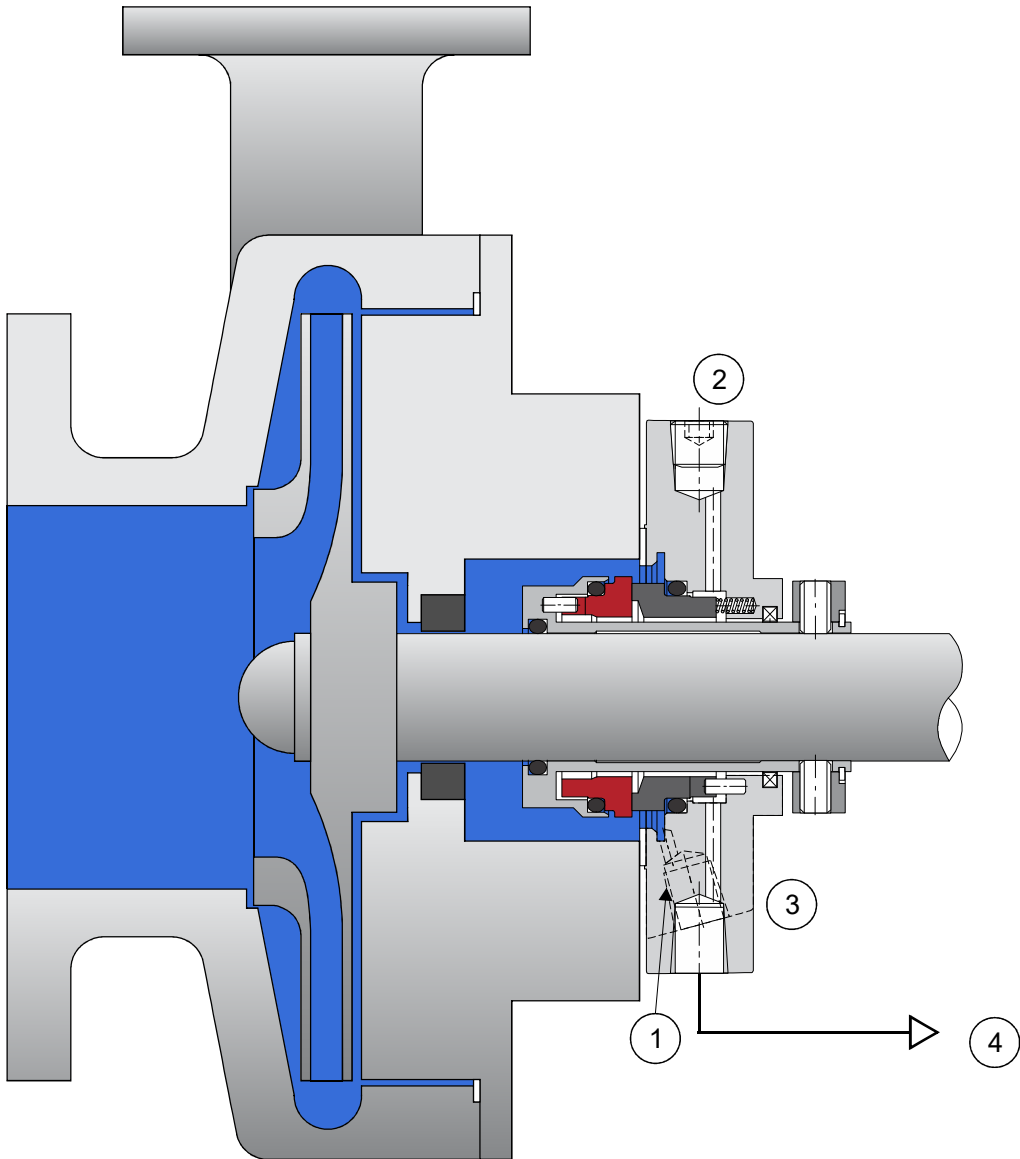

Description:

Plan 61 is a pre-fitted connection where a port is tapped for future planning.

Features:

- Drain connection can be piped to collect leakage (becomes Plan 65)
- Both Quench and Drain can be piped and used as quench in and out (becomes Plan 62)

Notes:

- For future provision
- Keep ports plugged until use of another plan

Key:

1. Flush port
2. Quench port
3. Drain
4. Line to collection point

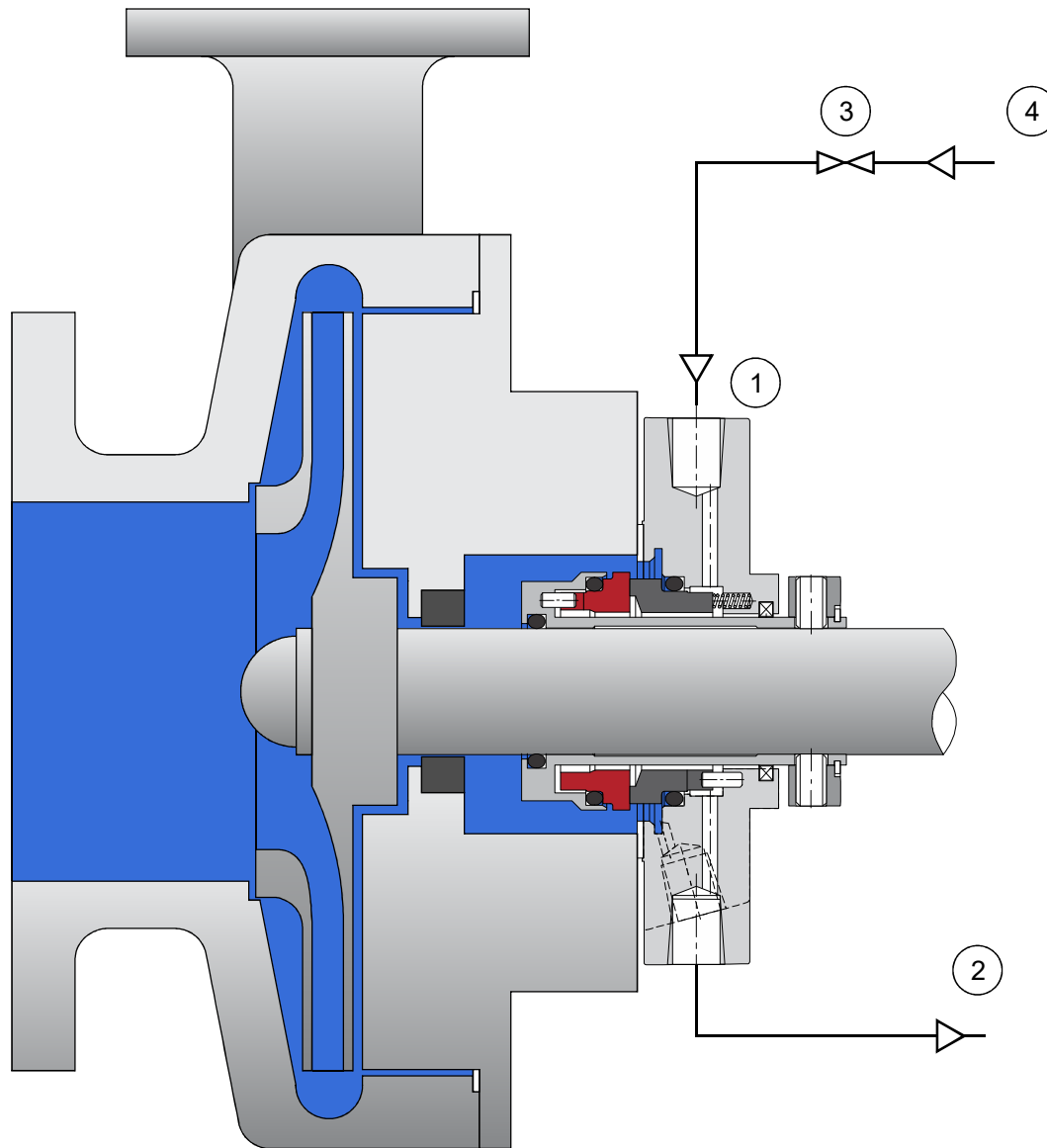

Description:

Plan 62 is a general plan to improve the environment on the atmospheric side of single seals by quenching with steam, nitrogen or water.

Features:

- The liquid quench acts as a disaster management drainage system in the event of seal failure
- Flushes any product build up under seal faces
- Can make use of water, steam or inert gas
- Assist with the cooling of the seal faces

Notes:

- Can be used with oxidizing fluids or hot hydrocarbons
- Quench fluid should be at a low pressure (maximum 1 bar)
- Recommended to use a throttle bush on atmospheric side
- Bearing isolators are necessary to prevent unwanted fluid entering the bearings

Key:

1. Quench port
2. Drain
3. Block valve
4. Line from external source



API PLAN 76

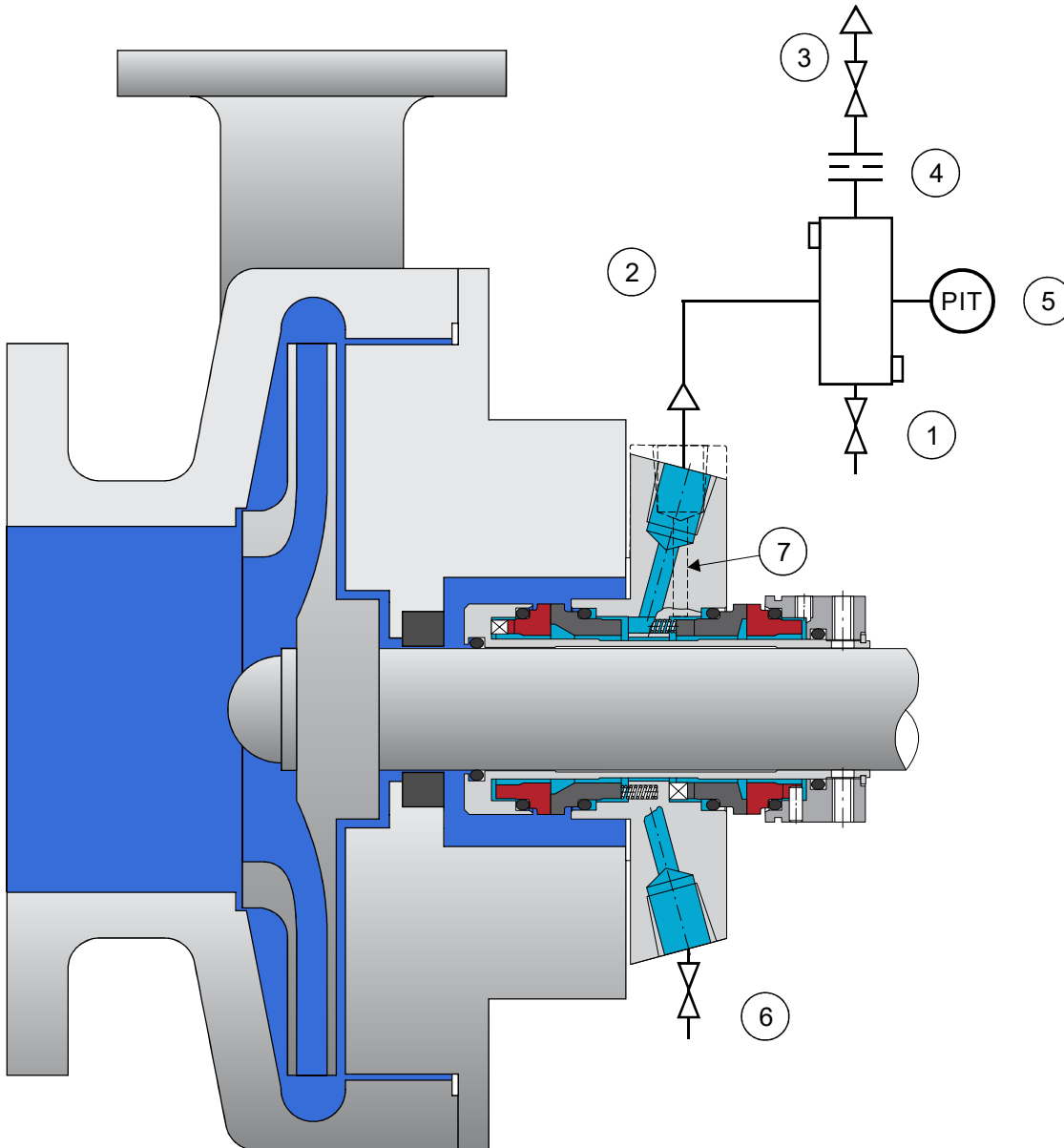

Description:

Plan 76 is a system to divert non-condensing primary seal leakage to a flare or vapor recovery system.

Features:

- Avoids direct leakage of product into the atmosphere and ensures almost no leakage from the outboard seal
- Vapors are directed to the vapor collection system
- Can be used with buffer gas (Plan 72) or without buffer gas (Plan 71)

Notes:

- Used if the product does not condense at ambient temperatures
- Set the pressure transfer alarm to trigger an alarm if the vapor pressure increases (indicates inboard leakage)
- Ensure a low point condensate drain
- Use a minimum ½" (13mm) tubing for the collection system vapor line
- Do not use for condensing product

Key:

1. Drain
2. Vent line
3. Collection valve
4. Orifice
5. Pressure indicator and transmitter
6. Containment drain
7. Gas buffer inlet