

S286



Materials

- Stationary - Car, SiC, SSiC, TC
- Rotary - SiC, SSiC, TC
- Elastomer - NBR, EPDM, Viton, Aflas, FFKM

Working Conditions

- Pressure < 40 bar
- Speed < 25 m/s
- Temperature up to 205°C

Features

- Stationary Design API682
- Monolithic Faces
- Cushioned Faces
- Double Pressure Balanced (Full pressure reversal)
- Springs outside the media
- Tandem
- Bi-Directional Pumping Device
- Multi-Flush Port
- Floating Quench
- Narrow Inboard Face
- Optional Hydro Pads

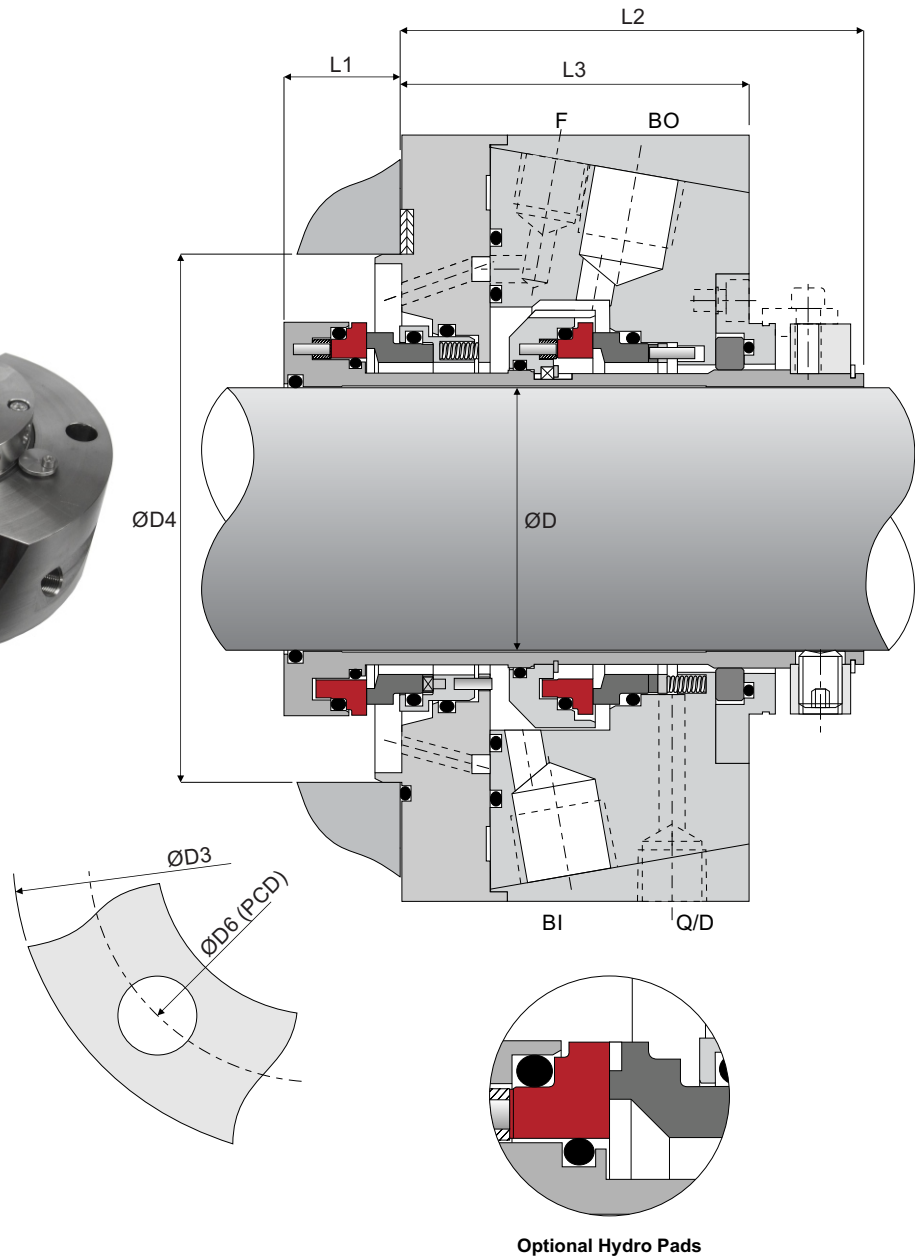
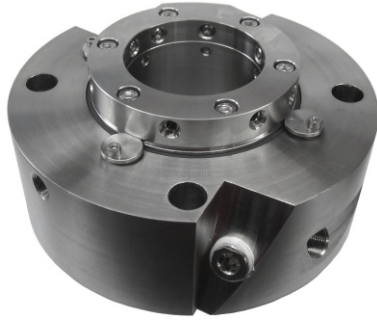

Seal Size	Shaft ØD MAX		ØD3		ØD4		STUD SIZE		ØD6 PCD		L1		L2		L3	
	mm	inch	mm	inch	mm	inch	mm	inch	mm	inch	mm	inch	mm	inch	mm	inch
1	20	(0.787)	130	(5.118)	70	(2.756)	M12x1.75	1/2"-13	105	(4.134)	33	(1.287)	95	(3.740)	73	(2.874)
2	30	(1.181)	140	(5.512)	80	(3.150)	M12x1.75	1/2"-13	115	(4.528)	33	(1.287)	95	(3.740)	73	(2.874)
3	40	(1.575)	150	(5.906)	90	(3.543)	M12x1.75	1/2"-13	125	(4.921)	33	(1.287)	95	(3.740)	73	(2.874)
4	50	(1.969)	170	(6.693)	100	(3.937)	M16x2.0	5/8"-11	140	(5.512)	33	(1.287)	105	(4.134)	73	(2.874)
5	60	(2.362)	190	(7.480)	120	(4.724)	M16x2.0	5/8"-11	160	(6.299)	33	(1.287)	105	(4.134)	73	(2.874)
6	70	(2.756)	200	(7.874)	130	(5.118)	M16x2.0	5/8"-11	170	(6.693)	33	(1.287)	105	(4.134)	73	(2.874)
7	80	(3.150)	210	(8.268)	140	(5.512)	M16x2.0	5/8"-11	180	(7.087)	33	(1.287)	105	(4.134)	73	(2.874)
8	90	(3.543)	240	(9.449)	160	(6.299)	M20x2.5	3/4"-10	205	(8.071)	33	(1.287)	115	(4.528)	73	(2.874)
9	100	(3.937)	250	(9.843)	170	(6.693)	M20x2.5	3/4"-10	215	(8.465)	33	(1.287)	115	(4.528)	73	(2.874)
10	110	(4.331)	260	(10.236)	180	(7.087)	M20x2.5	3/4"-10	225	(8.858)	33	(1.287)	115	(4.528)	73	(2.874)