

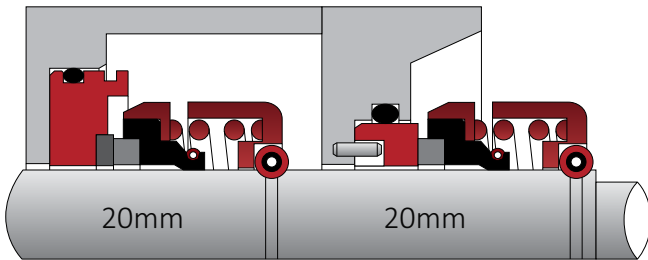

FLYGT COMPONENT SEALS

SFA-Upper & SFA-Lower

#2066 #2075 (De-watering) 2.2Kw or 3.7Kw



SFXA-Upper & SFXA-Lower

#2066 #2075 (De-watering) 2.2Kw or 3.7Kw

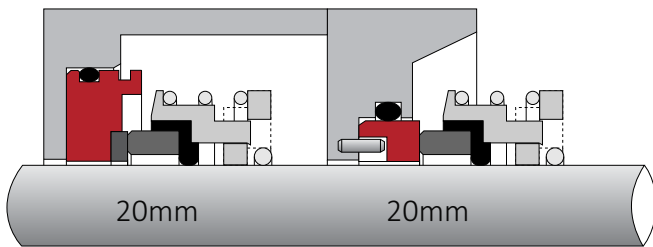

SFC-Upper & SFC-Lower

#2102 New (De-watering) 3.7Kw or 5.2Kw

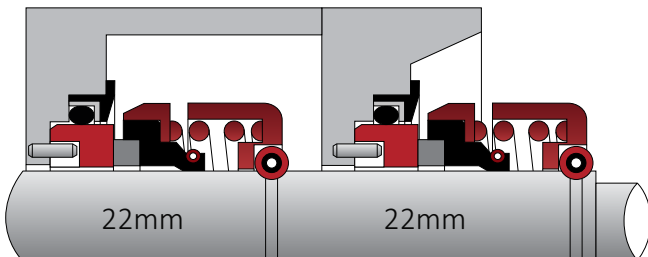

SFE-Upper & SFE-Lower

#2102 Old (De-watering) 3.7Kw or 5.2Kw

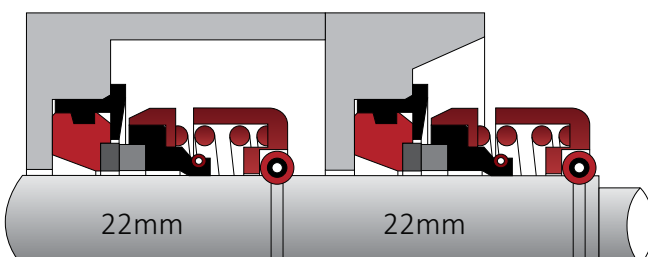



FLYGT COMPONENT SEALS

SFG-Upper & SFG-Lower

#3085 (Sewage) 2.4Kw

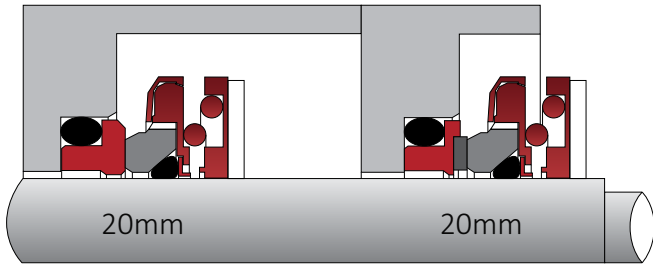

SFXG-Upper & SFXG-Lower

#3085 (.090 .091 .171 .181) 2.4Kw

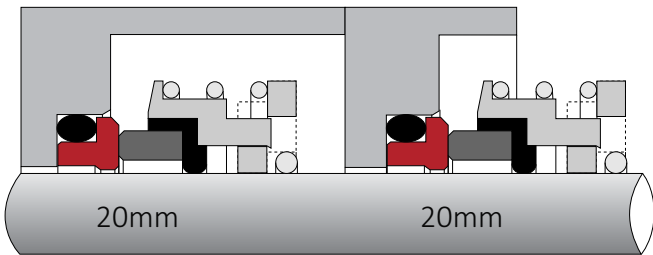

SFI-Upper & SFI-Lower

#2125 (De-watering) 8Kw

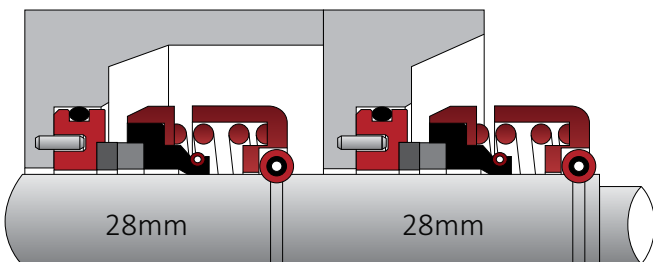

SFXI-Upper & SFXI-Lower

#2125 (De-watering) 8Kw

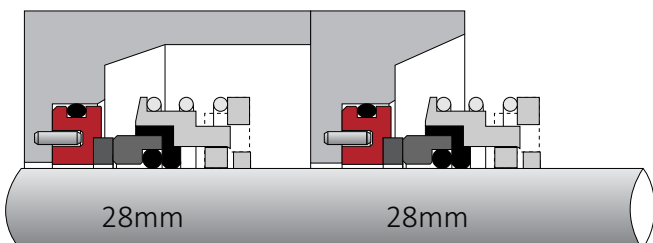



FLYGT COMPONENT SEALS

SFJ-Upper & SFJ-Lower

#3102 (Sewage) 3.1Kw

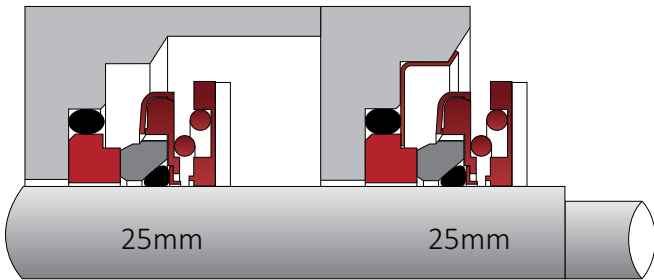

SFK-Upper & SFK-Lower

#2151 Old (De-watering) 20Kw

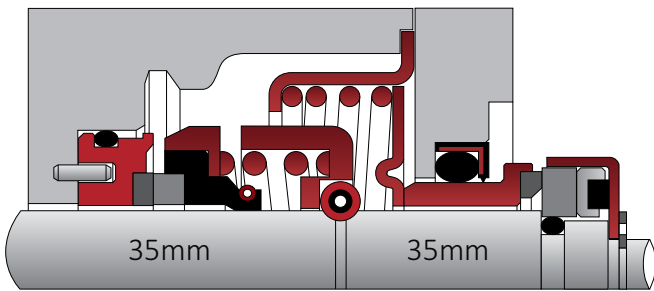

SFK-Upper & SFL-Lower

#2151 New (De-watering) 20Kw

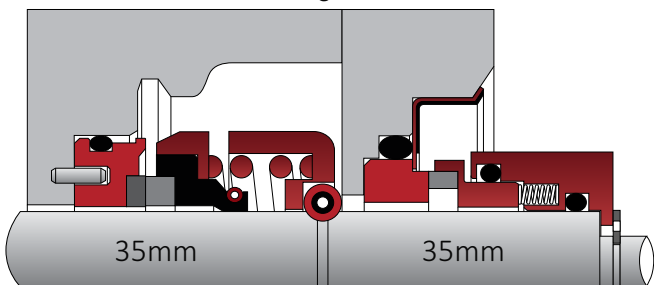

SFM-Upper & SFM-Lower

#3127 (Sewage) 5.7Kw or 7.4Kw

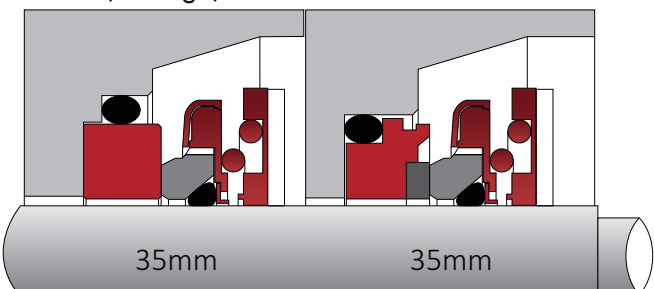



FLYGT COMPONENT SEALS

SFXM-Upper & SFXM-Lower

#3127 (Sewage) 5.7Kw or 7.4Kw

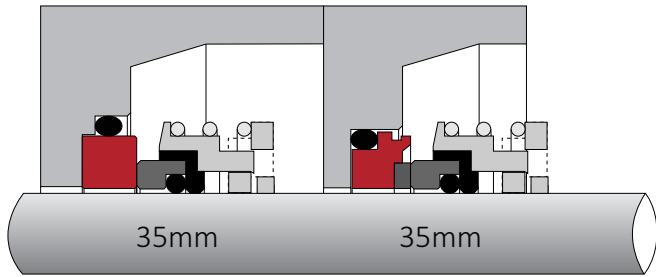

SFO-Upper & SFO-Lower

#3152 (Sewage) 13.5Kw

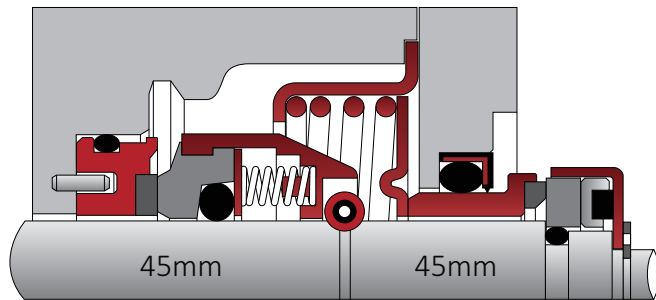

SFO-Upper & SFN-Lower

#2201 (De-watering) 37Kw

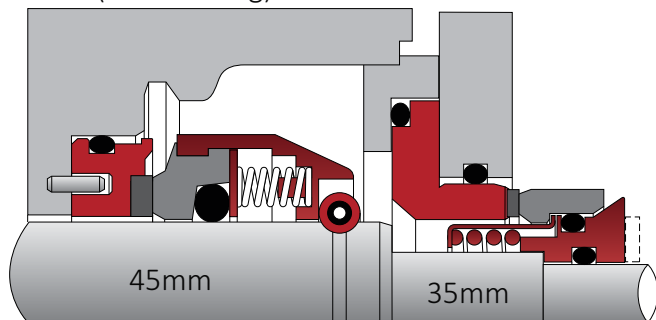

SFP-Upper & SFP-Lower

#2250 (De-watering) 54Kw

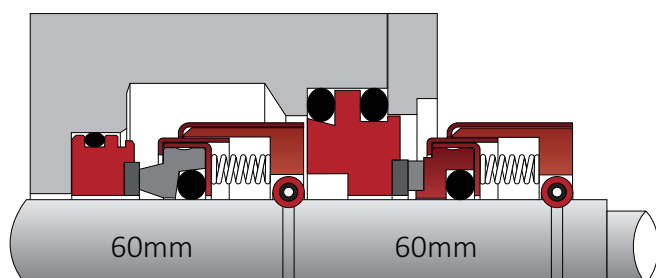

FLYGT COMPONENT SEALS



SFQ-Upper & SFQ-Lower

#3201 (Sewage) 22Kw or 30Kw

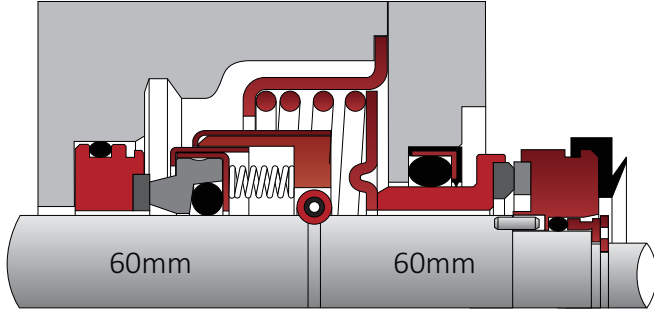

SFR-Upper & SFR-Lower

#2400 (De-watering) 90Kw

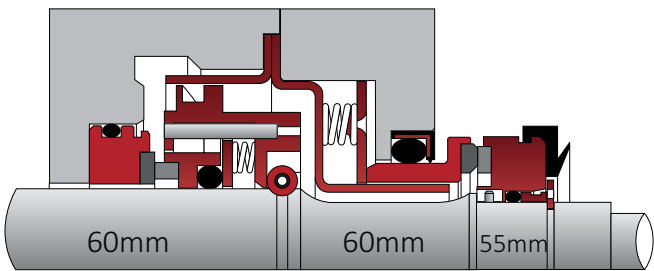

SFS-Upper & SFS-Lower

#3300 54Kw or 70Kw

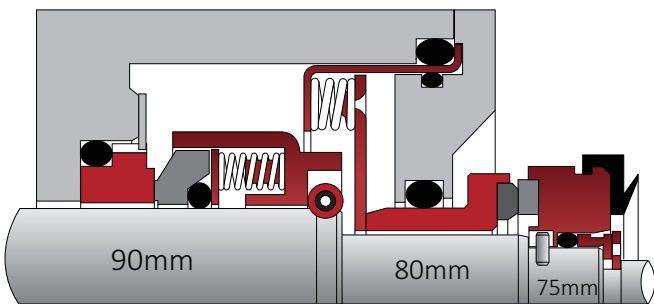

SFS-Upper & SFU-Lower

#3400

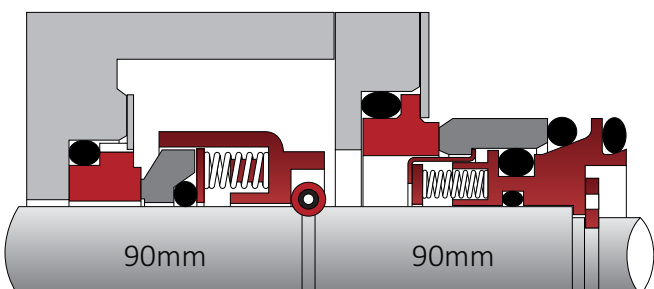



FLYGT COMPONENT SEALS

SFB-Upper & SFB-Lower

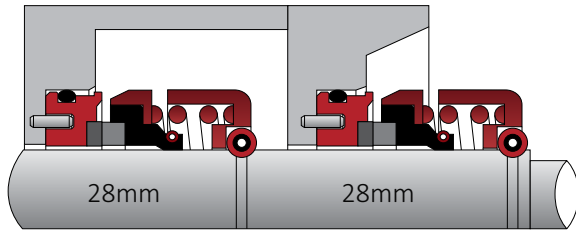

SFZ-Upper & SFZ-Lower

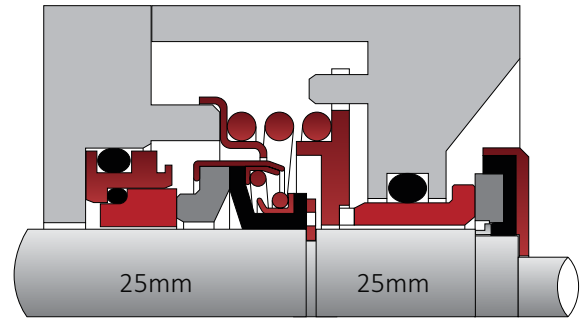

SFG-Upper & H-Lower Early Design

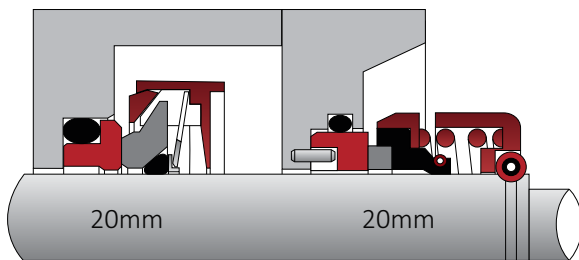

SFD-Double Seal

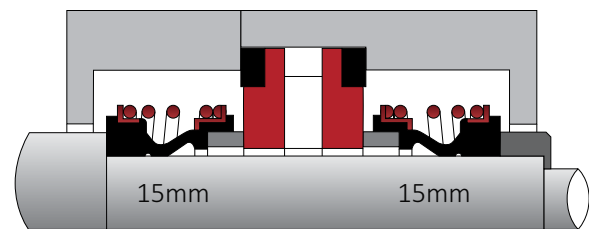

SFF-Upper & SFF-Lower

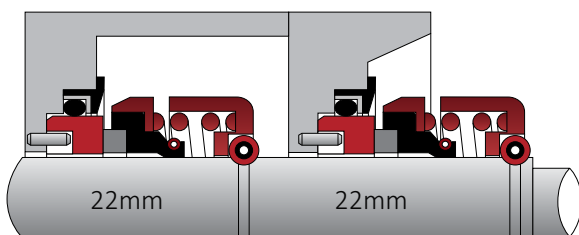

SFG-Upper & SFH-Lower Late Design

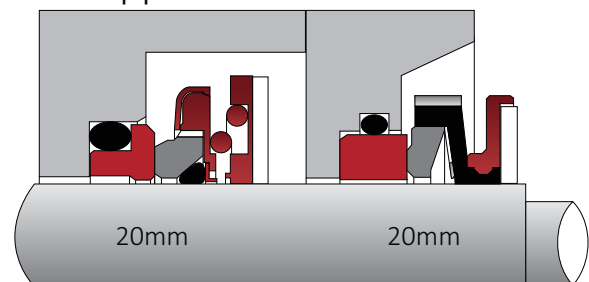

SFN-Upper & SFN-Lower

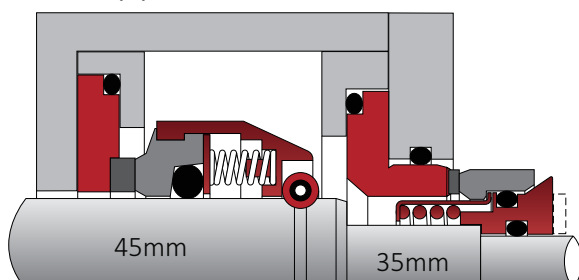

SFS-Upper & SFT-Lower

