



# SSV

## Materials

Face - Cer, Sic, SSic, TC

Elastomer - PTFE

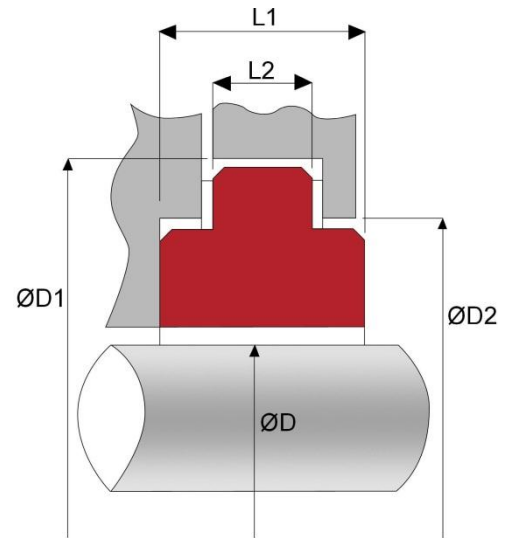

S10R/S10T Shaft ØD	Imperial		Seat ID	ØD1	ØD2	L1	L2
	Code	Shaft ØD					
16-19	0191	0.750	19.9	48	36.51	17.4	7.9
20-22	0222	0.875	23.0	51	39.69	17.4	7.9
23-25	0254	1.000	26.2	54	42.86	17.4	7.9
26-29	0317	1.250	32.6	68	50.8	26.9	11.1
30-32	0349	1.375	36.1	71	53.98	26.9	11.1
33-35	0381	1.500	39.3	78	57.15	26.9	11.1
36-38	0412	1.625	42.5	81	63.5	26.9	11.1
39-42	0444	1.750	45.7	84	66.68	26.9	11.1
43-45	0476	1.875	48.8	87	69.85	26.9	11.1
46-48	0508	2.000	52.0	97	73.03	26.9	11.1
49-51	0539	2.125	55.2	100	79.38	33.3	14.3
52-54	0571	2.250	58.4	103	82.55	33.3	14.3
55-58	0603	2.375	61.5	106	85.73	33.3	14.3
59-60	0635	2.500	64.7	110	88.9	33.3	14.3
61-64	0666	2.625	67.9	113	92.08	33.3	14.3
65-66	0698	2.750	71.1	116	95.25	33.3	14.3
67-70	0730	2.875	74.2	117	98.43	33.3	14.3
71-73	0762	3.000	77.4	121	100.01	33.3	14.3
74-76	0793	3.125	80.6	132	103.19	33.3	14.3